

EA63-4

Generator Automatic Voltage Regulator Operation Manual

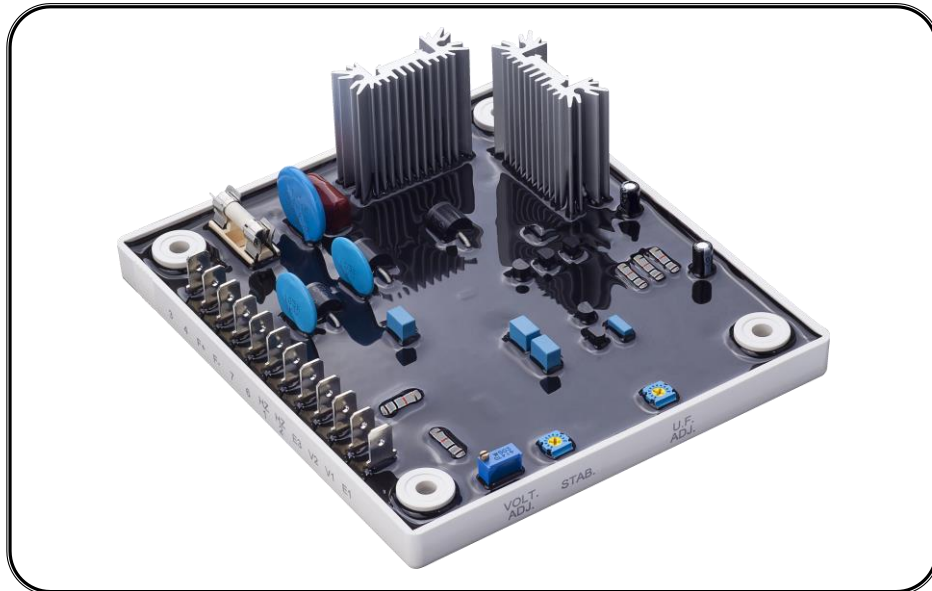

Self Excited Automatic Voltage Regulator
Compatible with Basler AVC63-4A*

* All manufacturer names and numbers are used for reference purpose only and do not imply that any part is the product of these manufacturer.

SECTION 1 : SPECIFICATION

Sensing Input

Voltage 95 – 139 Vac +/-10% @ 120 Vac
 190 – 277 Vac +/-10% @ 240 Vac
 Frequency 50 / 60 Hz, selectable

Power Input

Voltage 95 – 139 Vac +/-10%, 1 phase 2 wire
 Frequency 45 / 65 Hz

Excitation Output

Voltage Max. 63 Vdc
 Current Continuous 4A
 Intermittent 7A for 60 secs.
 9A for 10 secs.
 Resistance Min. 15 ohm Max. 100 ohm
 Fuse Spec. Slow blow 5 x 20mm S505-6.3A / 250V

External Voltage Adjustment

Max. +/- 15% @ 10K ohms 1 watt potentiometer

Voltage Regulation

Less than +/- 1% (with 4% engine governing)

Build Up Voltage

5 Vac residual volts at power input terminal

EMI Suppression

Internal electromagnetic interference filtering

Static Power Dissipation

Max.15 watts

Under Frequency Protection (Factory Presets)

Knee point adjustable range 45 – 55 Hz

Over Excitation Shutdown

Field volts shut down after a time delay
 If exciter field volts exceed 95 Vdc +/- 5%

Voltage Thermal Drift

Less than 3% at temperature range -40 to +70 °C

Environment

Operating Temperature -40 to +60 °C
 Storage Temperature -40 to +85 °C
 Relative Humidity Max. 95%
 Vibration 1.5 Gs @ 5 – 30 Hz
 5.0 Gs @ 30 – 500 Hz

Dimensions

140.0 (L) x 125.0 (W) x 48.0 (H) mm

Weight

280 g +/- 2%

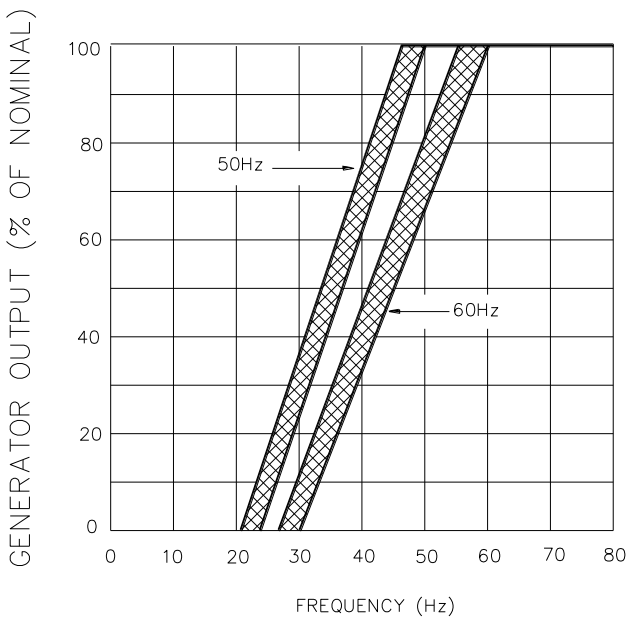

Frequency Compensation Curves
 Figure 1

V/Hz “CORNER FREQUENCY” SELECTION AND ADJUSTMENT

For 60 Hz systems, the regulator is preset at the factory for a 55 Hz “corner frequency”. For 50 Hz systems, a 45 Hz “corner frequency” is achieved by connecting a jumper across terminals Hz 1 and Hz 2.

The corner frequency can be adjusted by the U/F ADJ rheostat on the AVR. Clockwise rotation results in raising the corner frequency (shifting the curve to the right). To set the UF rheostat :

1. Adjust the UF Rheostat fully CCW.
2. Start the generator and set at rated voltage.
3. Adjust the generator frequency to the desired kneepoint frequency.
4. Slowly adjust the U/F ADJ rheostat clockwise (CW) until the generator voltage just begins to decrease.

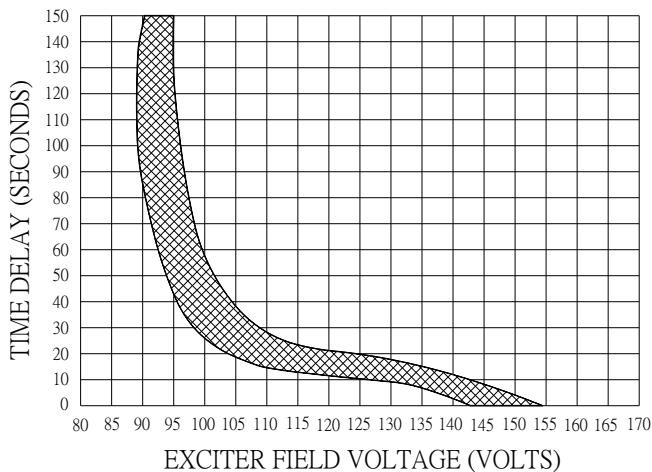

Typical Time Delay Characteristic Curve
Figure 2

OVEREXCITATION SHUTDOWN

Overexcitation shutdown is included that removes the output power if the exciter field voltage exceeds 95 Vdc. If exciter field voltage exceeds 95 Vdc +/- 5%, the regulator automatically removes field current, after a time delay. The time delay is inversely proportional to the magnitude of the detected overvoltage condition. At 134 Vdc, the field voltage is removed after approximately 10 seconds. Refer to the following figure.

After output power is removed, the regulator can be reset by decreasing the input voltage to less than 6 Vac for a minimum of 2 seconds; this may be accomplished by stopping the prime mover or by interrupting the regulator input with a reset switch.

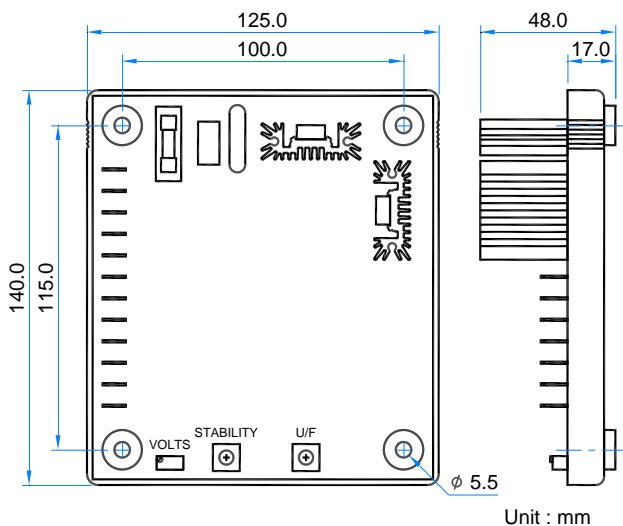

Figure 3 Outline Diagram

ATTENTION

1. AVR can be mounted directly on the engine, genset, switchgear, control panel, or any position that would effects operation. For mounting, please see Figure 2.
2. All voltage readings are to be taken with an average-reading voltmeter Meggers and high-potential test equipment must not be used. Use of such equipment could damage the AVR.
3. Improper setting of under-frequency protection could cause the output voltage of the unit to drop or become unstable under with changes in load. Avoid making any changes to the U/F setting unless necessary.

SECTION 2 : OPERATION PROCEDURE

2.1 Stability Adjust Rheostat (STAB)

- 2.1.1 An internal screwdriver adjustable potentiometer provides adjustment to the response rate of the generator output voltage to a change in load.
- 2.1.2 Clockwise rotation of this adjustment provides an increase in the response time and therefore decreases the amount of voltage overshoot (increased stability). Counter-clockwise rotation of this adjustment provides a decrease in the response time (faster response time) and therefore increases the amount of voltage overshoot (decreased stability).

2.2 Operation

The following system operation procedures provide instructions for adjusting the EA63-4 voltage regulator. Symptoms resulting from a faulty regulator and certain generator system problems are included, together with suggested remedies.

CAUTION

Meggers and high potential test equipment must not be used. Incorrect use of such equipment could damage the semiconductors contained in the regulator.

2.3 Preliminary Set-Up

- 2.3.1 Verify that the voltage regulator specifications conform with the generator system requirements.
- 2.3.2 Ensure that the regulator wires are as follows:
 - If the remote voltage adjust rheostat is not to be connected, ensure terminals 6 and 7 are shorted with a jumper.

- If a 55 Hz “corner frequency” for 60 Hz systems is desired, ensure that the Hz 1 and Hz 2 terminals are open. If a 45 Hz “corner frequency” for 50 Hz systems is terminals are shorted together with a jumper.
- For 120V nominal sensing, ensure that terminals V1 and V2 are not connected. For 240V sensing, ensure that terminals V1 and V2 are connected together.

2.3.3 Ensure the voltage regulator is correctly connected to the generator system.

2.3.4 Install the fuses as described in Fuses.

2.3.5 Set the regulator VAR and external VAR (if used) as follows :

SWITCH	INITIAL SETTING
Regulator VAR	Fully CCW
Remote VAR	Centered

2.4 System Star-Up

2.4.1 Perform preliminary set-up as described in the above paragraphs.

NOTE :

All voltage readings are to be taken with an average reading voltmeter.

2.4.2 Start prime mover and bring up to rated speed.

RESULT :

Voltage should build up. If not, perform Field Flashing.

2.4.3 Slowly adjust the regulator VAR CW until the generator output voltage reaches the nominal value. If used, adjust the remote VAR to set the generator voltage to the exact value desired.

RESULT :

Voltage should build up to rated value. If voltage does not build up to rated value, check generator for short or excessive load.

2.4.4 Check regulator normal operating and loading conditions.

RESULT :

Voltage regulation should be better than +/- 1.0% no-load to full-load. If regulation is not within this range, perform the following steps :

- Voltage reduction under load may be due to speed change from no load to full load. causing the frequency compensation (U/F) circuit to reduce voltage at lower frequencies.

- Replace voltage regulator.

WARNING

Please make sure you have read and understand the contents of the instruction manual prior to installation. Incorrect wiring connection may result in irreversible damage to the product and other equipments.

2.5 Operational Test

2.5.1 Connect the test setup as shown in the following figure, Operational Test. Do not apply power. Ensure that the light bulb is rated for 120V and is less than 100W.

Complete the following steps before proceeding with the system start-up.

2.5.2 Adjust the regulator VAR and/or remote VAR, and the STABILITY Adjust to maximum CCW.

2.5.3 Apply 120V, 50/60 Hz power to the regulator. The light bulb should illuminate.

2.5.4 Slowly adjust the regulator VAR control CW. At the regulation point, the light bulb should extinguish. Small adjustments above and below this level should cause the light bulb goes on and off rapidly.

2.5.5 Rotate the STABILITY ADJ fully CW. Now adjust the regulator VAR above and below the regulation point. The light bulb should still to off and on, but the transition from off to on (and vice versa) should be much slower than in the paragraph above.

The following notes (Δ) apply to the interconnection diagrams :

- (1) If external pot is not used, short terminals 6 and 7.
- (2) For 50 Hz, short terminals Hz 1 and Hz 2 and leave open for 60 Hz.
- (3) Item not supplied by KUTAI ELECTRONICS.
- (4) For 120V Nominal sensing, make no connection to terminals V1 and V2.
For 240V Nominal sensing, short terminals V1 and V2 together.
- (5) Select fuses with high interrupting capacity.

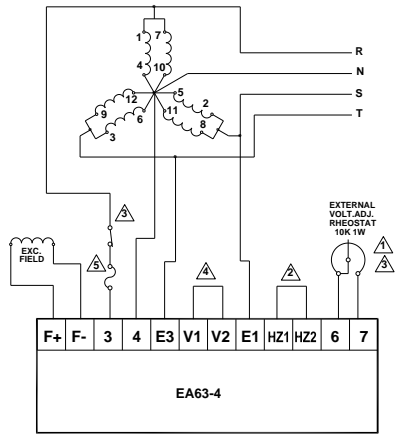

Interconnection Diagram, 127 / 220 V Nominal,
3-phase, 4-Wire
Figure 4

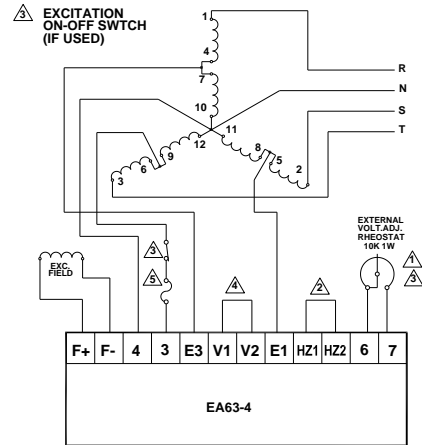

Interconnection Diagram, 277 / 480 V Nominal,
3-phase, 4-Wire
Figure 5

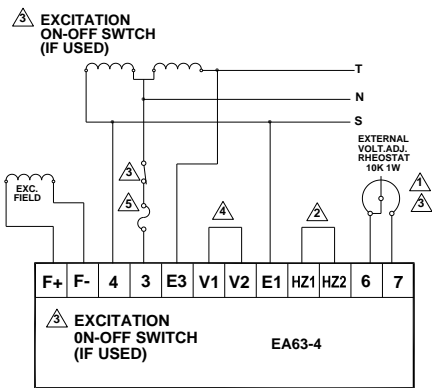

Interconnection Diagram, 127 / 220 V Nominal,
1-phase, 3-Wire
Figure 6

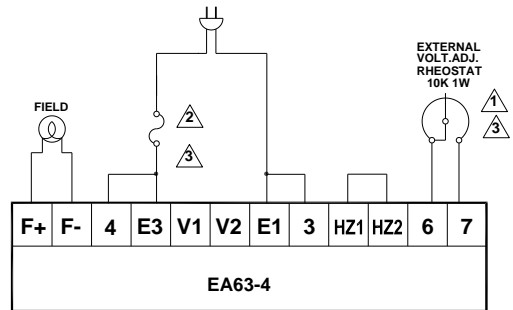

NOTE : IF GLASE TYPE FUSE IS USED
ENCLOSE FOR SAFETY
Operational Test

Figure 7