

CH4612 / CH4624

Automatic Battery Charger

Wide Input Range 100 to 277 Vac



Features

- UL1236 listed Intelligent switch mode battery charger
- Automatic charging under all conditions
- Elevated component temperature will automatically reduce output power
- Low battery voltage monitor with solid state battery negative alarm output
- Charging current and voltage display
- Short circuit & reverse polarity protections
- No current drain when input power is off
- Built-in AC power input micro fuse protection
- Panel Mount or DIN Rail



CH4612 / CH4624
www.kutai.com.tw

Specifications

Power Input	Voltage	100 to 277 Vac	Efficiency	More than 80% @ full load	
	Frequency	47 to 63 Hz		Protection	Constant output voltage, limited charge current
	Current	CH4612 1.6A CH4624 1.8A			reverse polarity and short circuit protections
DC Output	CH4612	13.8 Vdc 5A Max.	Environment	Operation Temperature -20 to +60 °C	
	CH4624	27.6 Vdc 3A Max.		Storage Temperature -30 to +80 °C	
DC Voltage Regulation	Less than +/-1%			Relative Humidity Max. 90%	
Charge Mode	Float		Dimensions	Vibration 5.0 Gs @ 60 Hz	
Alarm Output Capacity	0.5A @ 40 Vdc			175.0 (L) x 115.0 (W) x 60.0 (H) mm	
Suitable Battery Type	Gel, Lead Acid & AGM			7.0 (L) x 4.5 (W) x 2.4 (H) inch	
			Weight	0.52 kg (1.15 lb) +/-2%	

Dimensions

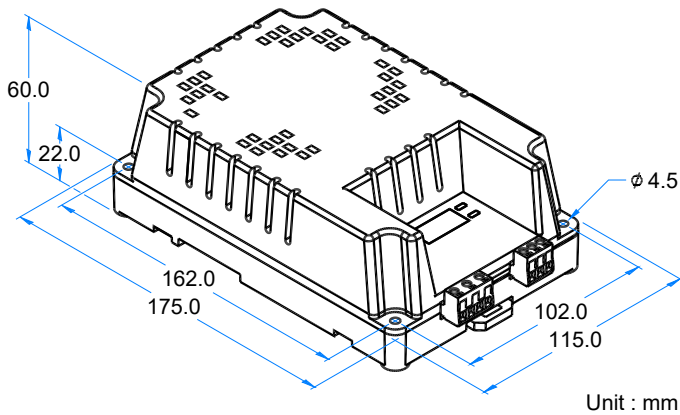

Display & Alarm Indicators

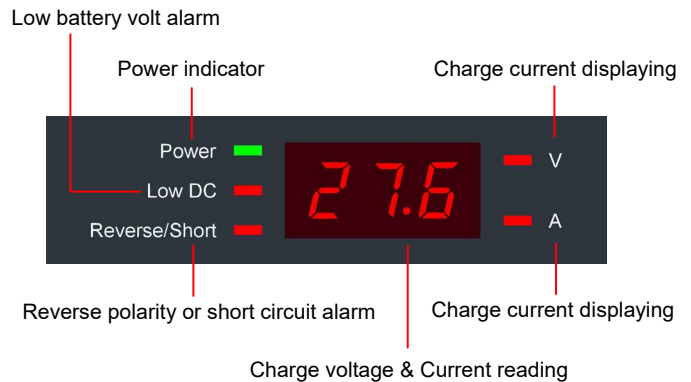

DIN Rail Assembly Instructions

Charger Installation

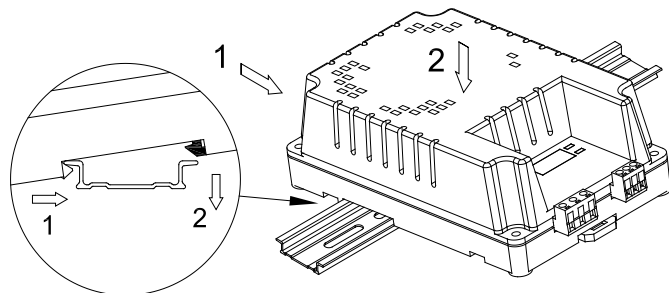

Dismount Charger

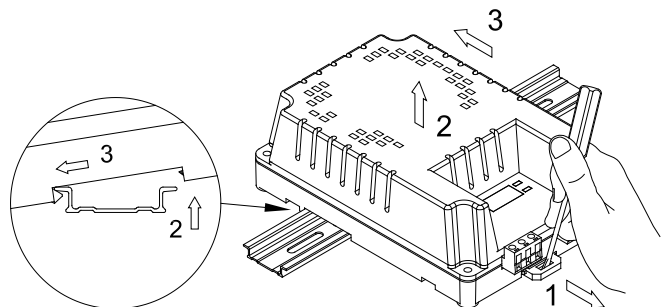

KUTAI ELECTRONICS INDUSTRY CO., LTD.
 TEL : +886-7-8121771 FAX : +886-7-8121775 Website : www.kutai.com.tw
 Headquarters : No.3, Ln. 201, Qianfu St., Qianzhen Dist., Kaohsiung City 80664, Taiwan

